



● Daikin products are manufactured for export to numerous countries throughout the world. Prior to purchase, please confirm with your local authorised importer, distributor and/or retailer whether this product conforms to the applicable standards, and is suitable for use, in the region where the product will be used. This statement does not purport to exclude, restrict or modify the application of any local legislation.

● Use only those parts and accessories supplied or specified by Daikin.

Read the User's Manual carefully before using this product. The User's Manual provides important safety instructions and warnings. Be sure to follow these instructions and warnings.

If you have any enquiries, please contact your local importer, distributor and/or retailer.



PLXSID1605

SkyAir

AIR CONDITIONING SYSTEM

COOLING ONLY [50Hz]



Dealer

PT. DAIKIN AIRCONDITIONING INDONESIA

Head Office:
Wisma KEIAI, 18th Floor
Jl. Jendral Sudirman Kav 3, Jakarta Pusat 10220
Telp : +6221-572 4377
Fax : +6221-572 4366/55
Website : <http://www.daikin.co.id>

Service and Spare Parts, Telp.: 021-736 92899 • Training Center, Telp.: 021-295 61950 • Bandung, Telp.: 022-601 4781 • Semarang, Telp.: 012-841 2695 • Surabaya, Telp.: 031-503 1138 • Denpasar, Telp.: 0361-900 5514 • Makassar, Telp.: 0411-446 263 • Palembang, Telp.: 0711-319 776

Daikin Contact Center: 0800 1 081 081 (Toll Free)

R-410A



The solution for light commercial sector

Providing the ideal solution for all kinds of small commercial space such as shops, restaurant and small offices. The Sky Air series offers a complete comfort solution that puts you in total control.



Product Lineup

Capacity	PK	2.0	2.5	3.0	3.0	3.5	4	5
	Btu/h	18500	23000	28000	28000/29000*	36000	42000	55000
	kW	5.4	6.7	8.2	8.2/8.5*	10.5	12.3	16.1
Ceiling Cassette Type								
Indoor unit		FCRN50FXV14	FCRN60FXV14	FCRN71FXV14	FCRN71FXV14	FCRN100FXV14	FCRN125FXV14	
Outdoor unit		RN50CXV1A4	RN60CXV1A4	RR71CXV1A4	RR71CXY1A4	RR100DXY1A4	RR125DXY1A4	
Floor Standing Type								
Indoor unit				FVRN71BXV14	FVRN71BXV14	FVRN100BXV14	FVRN125BXV14	FVRN140BXV14
Outdoor unit				RR71CXV1A4	RR71CXY1A4	RR100DXY1A4	RR125DXY1A4	RR140DXY1A4
Outdoor Unit								
		RN50CXV1A4	RN60CXV1A4	RR71CXV1A4	RR71CXY1A4	RR100DXY1A4	RR125DXY1A4	RR140DXY1A4

*Only applicable for Floor Standing Type

Ceiling Cassette Type

4 way air flow ceiling cassette



FCRN50/60/71/100/125FXV14



Wired Controller: BRC51A
* Optional

Wireless Controller: BRC52A
* Supplied with panel



COMFORT						CLEANLINESS	WORK & SERVICING	CONTROL FEATURES			OPTIONS			
Auto swing	Swing pattern	Switchable fan speed	Programme "Dry"	Two selectable temperature sensor	Timer selector	Weekly scheduled timer	Washable saranet filter	Drain pump mechanism	Pre-charged for up to 7.5m	Self diagnosis	Auto random restart	Group control by Network Interface Module (NIM)	External command control using G-way or BAG	Fresh-air intake kit
●	●	●	●	*1	●	*1	●	●	●	●	●	●	●	●

*1 Applicable when wired controller is used.

4-way air flow

This unit promotes even air distribution covering every corner of the room by combining 4-ways air discharge and large discharge area.

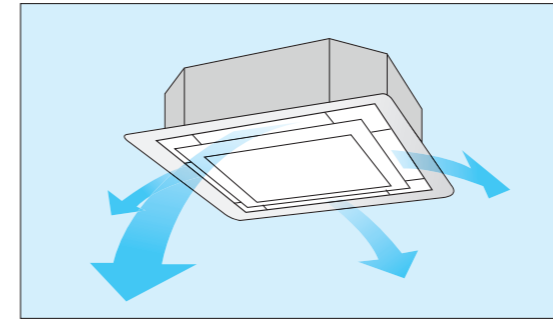

Compact body and quiet operation

Indoor units as an aerodynamically designed Difuser Turbo Fan.



Fine square panels

Panel size is same for all models. It is easy to maintain a neat appearance when multiple units are installed.

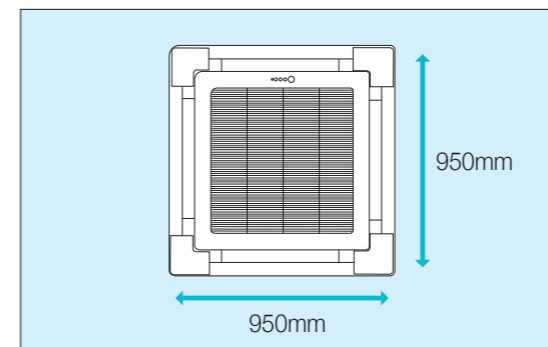

Draft resistance has been reduced by incorporating into a single unit, an impeller and a diffuser to control air flow inside the unit. The Diffuser Turbo Fan is both quiet during operation and compact.

Indoor Unit	Low dB(A)	Quiet dB(A)
FCRN50F	33	29
FCRN60F	34	31
FCRN71F	35	32
FCRN100F	37	34
FCRN125F	41	37

Optimal comfort and convenience assured by air discharge modes

To increase the comfort level of the air conditioned area, the system is built-in with 3 different types of air flow pattern to suit different requirements.

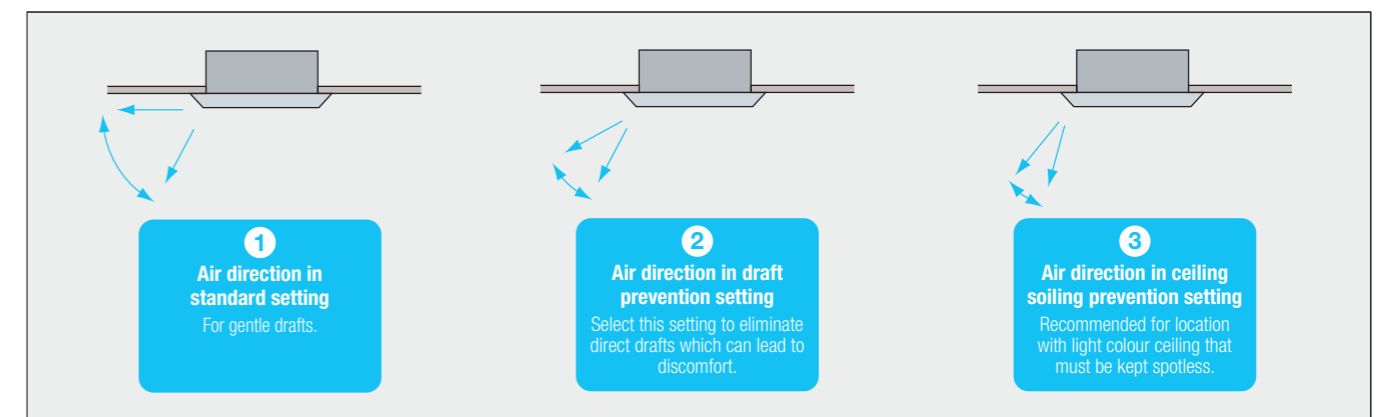

The default setting for air swing pattern is 1. The air swing pattern can be selected through the wireless remote control.

Two selectable temperature sensors

Both indoor unit and wired remote controller (option) contain temperature-sensors. Temperature sensing can be set at the unit or, to further improve comfort level, closer to the target area at the wired remote control. This feature must be set during commissioning by the technicians.

* Temperature-sensor on indoor unit must be used when the air conditioner is controlled from another room.

**Wireless remote controller does not have a temperature-sensor.

Switchable fan speed:

High → Medium → Low → Quiet

High setting provides maximum reach while low setting minimises drafts.

Timer selector

Operation starts when the preset time of the ON timer elapses and stops when the preset time of the OFF timer elapses.

Powerful operation

New powerful operation boosts airflow to maximum volume for a 20-minute period **with highest fan speed**. After this, the unit automatically returns to its previous settings.

Easy Installation

Quick and easy to install

Just 246mm high. Installable in tight ceiling spaces.

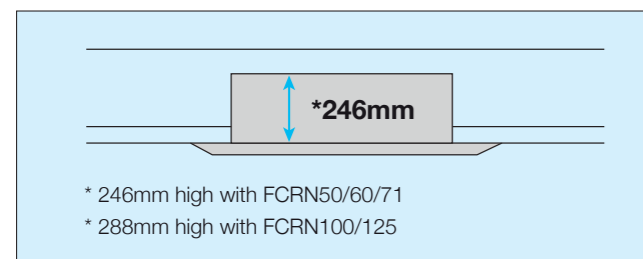

All models can be installed without using lifter because of the light weight.

Detachable corner

For the ease and flexibility of installation, this unit is designed with 4 detachable corners where installer is able to fit their hand in to adjust hanging hook and perform drain leakage check.

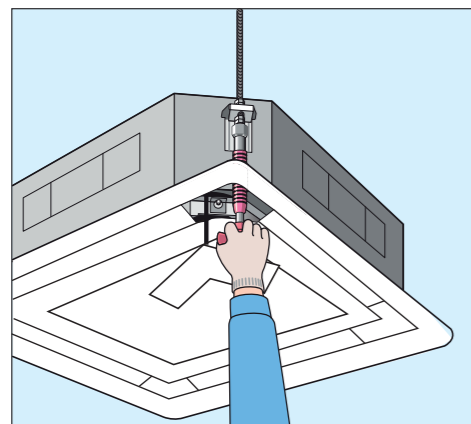

Indoor unit ON/OFF switch

The unit can be conveniently started manually in the event the wireless remote controller is misplaced or the wireless remote controller batteries are not charged.

Extra protection

This unit covered with insulation material acts as extra protection when installed under very high humidity environment to prevent condensation.

Panel-hook mechanism

This feature enables the installer to work with both hands as the panel can be hung on the unit.

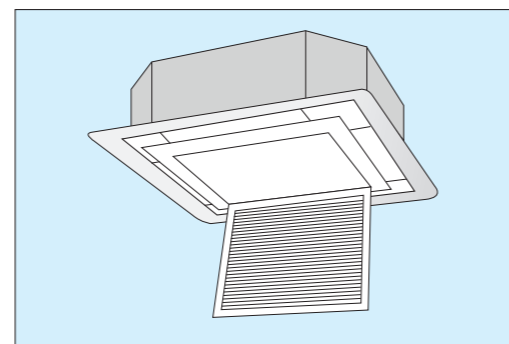

Position of connecting pipe and drain hose

In order to create more space for installer to work on connection pipe of indoor unit, the connection pipe of gas and liquid are located further from each other and purposely not align to hanging hook.

To enhance the convenience of installation, drain hose location is relocated to another side of cassette unit (not same side with connection pipe)

Easy accessible control box

Control box of this unit can be accessed directly from the intake grille for ease of installation and servicing process.

Drain pump is equipped as standard accessory with 700mm lift

This unit comes with a condensate water drain pump which can pump water up to 700mm higher from drain pipe outlet. Safety float is incorporated to monitor water level.

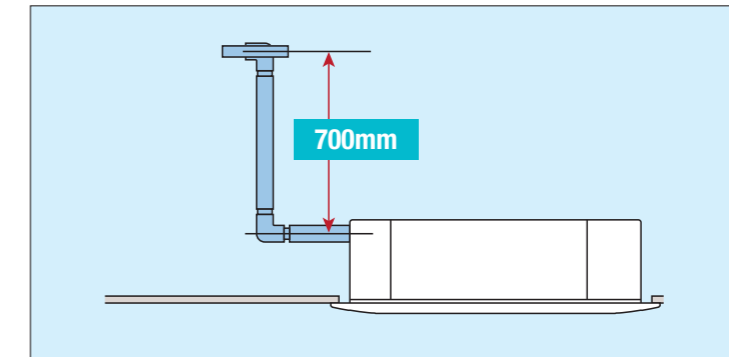

Easy Maintenance

Easier to maintain

The condition of the drain pan and drain water can be checked by removing the drain plug and intake grille.

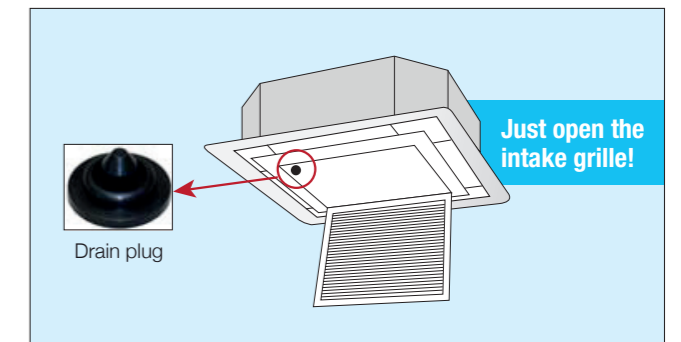

Simple step to change fan motor

- Without removing panel, it can be easily access and service to fan motor
- Reduced troubleshooting and servicing time
- Three simple steps:



Control box → Fan cover → Blower fan → Fan motor

Self-diagnosis function

This intelligent feature helps to detect faults or malfunctioning in the system and give user a warning by blinking of the LED light or display error code on wired controller.

Options required for specific operating environments

Fresh air intake kit

Using this kit*, a duct can be fitted to increase the intake of outdoor air.

Knock-out hole

The built-in knock-out hole are available for fresh air intake or branch duct.

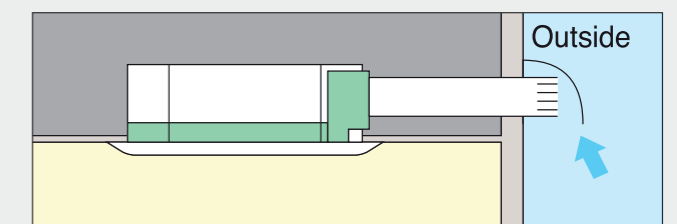

*Note: *Connecting ducts, insect nets, fire dampers, air filters, and other parts should, as required, be procured locally.*

Floor Standing Type

The floor standing is designed to look sleek, stylish and modern to blend into any environment. Its slim profile promotes an ideal way of space saving with style and functionality. Its high gloss finishing makes it easy for cleaning. With its ease of installation, it is suited to be installed in offices, commercial shops, restaurants, showrooms and mosque.

FVRN71/100/125/140FXV14



Wired Controller: BRC51A
* Optional

Wireless Controller: BRC52A
* Supplied with unit



Far air flow

The Daikin floor standing is able to achieve air flow distance as far as 25m* which is about the size of a basketball court.

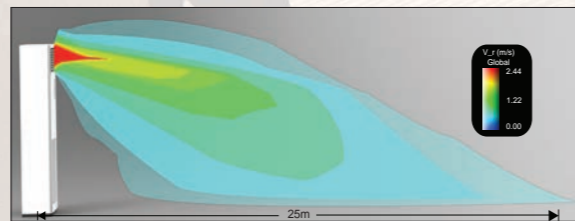

COMFORT						CLEANLINESS	WORK & SERVICING	CONTROL FEATURES			
Auto swing	Switchable fan speed	Programme "Dry"	Two selectable temperature sensor	Timer selector	Weekly scheduled timer	Washable saranet filter	Pre-charged for up to 7.5m	Self diagnosis	Auto random restart	Group control by Network Interface Module (NIM)	External command control using G-way or BAG
●	●	●	*1	●	*1	●	●	●	●	●	●

*1 Applicable when wired controller is used.

Auto-swing mode

This unit uses its automatic horizontal swing louver to spread comfortable air flow to cool every corner of the room. Its vertical louvers are adjusted manually to match different interior spaces and partition as well as to avoid direct airflow.

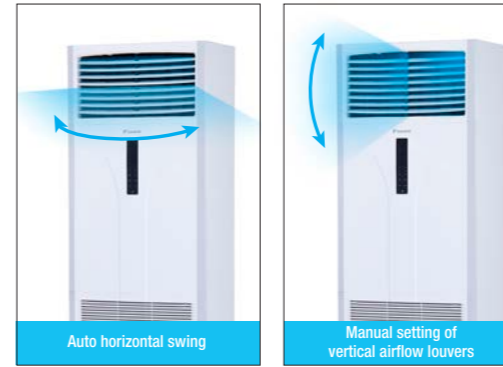

User-friendly controls

The unit comes with a stylish black control panel with white LED light for clear display. It comes with a keylock function to prevent setting change from unauthorised personnel.

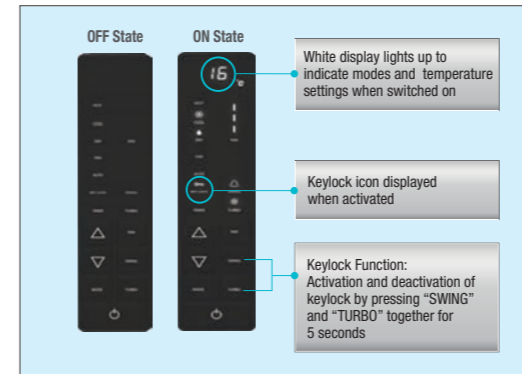

Additionally, this unit is incorporated with infrared sensor for usage with wireless controller (BRC52A62) which comes with the unit as the standard package. Thus, it can also be controlled using wireless controller for the flexibility in controls.



Two selectable temperature sensors

Both indoor unit and wired remote controller (option) contain temperature-sensors. Temperature sensing can be set at the unit or, to further improve comfort level, closer to the target area at the wired remote control. This feature must be set during commissioning by the technicians.

* Temperature-sensor on indoor unit must be used when the air conditioner is controlled from another room.

**Wireless remote controller does not have a temperature-sensor

Switchable fan speed:

High → Medium → Low

High setting provides maximum reach while low setting minimizes drafts.

Timer selector

Operation starts when the preset time of the ON timer elapses and stops when the preset time of the OFF timer elapses.

Powerful operation

New powerful operation boosts airflow to maximum volume for a 20-minute period **with highest fan speed**. After this, the unit automatically returns to its previous settings.

Indoor unit ON/OFF switch

The unit can be conveniently started manually in the event the wireless remote controller is misplaced or the wireless remote controller batteries are not charged.

Easy Maintenance

Safety clip

The safety clip feature allows the users to remove the washable saranet filter with ease during maintenance. At the same time, it also acts as a safety feature to prevent the users from reaching into the electrical and mechanical components.



Space for water drain pump

There is a space in the unit below the fan that allows users to install an external condensate water pump.

* The condensate water drain pump is separately purchased and field installed.



Outdoor Unit



RN50CXV1A4
RN60CXV1A4

RR71CXV1A4
RR71CXV1A4

RR100DX1A4
RR125DX1A4
RR140DX1A4

Fitted with wide inlet fan

Fully shaped aerodynamic propellers are designed to push air with a large wing surface, providing both high flow volume and quiet operation with turbulence.



Wide inlet fan

Equipped with scroll compressor for quiet operation

Smooth running, minimal vibration, low operating sound.
* Only applicable to RR100/125/140DX1A4

Outdoor		RN50C	RN60C	RR71C (1PH)	RR71C (3PH)
Sound Pressure Level	dB(A)	52	52	56	56

Outdoor		RR100D	RR125D	RR140D
Sound Pressure Level	dB(A)	58	60	65

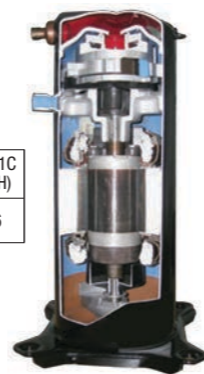

Installation and Maintenance

Pre-charged for up to 7.5 metres

Model	Pre-charged Piping Length, m	Max. Piping Length, m	Max. Piping Elevation, m
RN50C	7.5	30	15
RN60C	7.5	30	15
RR71C(1PH)	7.5	45	25
RR71C(3PH)	7.5	45	25
RR100D	7.5	50	30
RR125D	7.5	50	30
RR140D	7.5	45	25

Durability

- The unit is covered with corrosion-proof galvanized steel to enhance its durability.
- Heat exchange fins are provided with anti-corrosion treatment.

Controllers

Wireless controller BRC52A

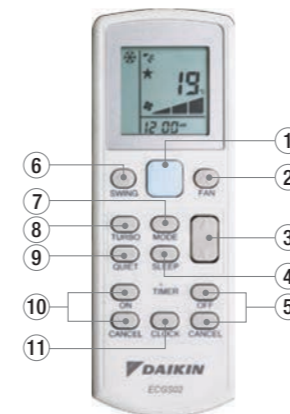

- ① "Glow-in-the-dark" ON/OFF switch
- ② Fan speed selection: Low, Medium, High, Auto
- ③ Temperature setting: Up & down
- ④ Sleep mode function
- ⑤ Off timer setting
- ⑥ Vertical auto-swing
- ⑦ Selectable mode: Cool, Dry, Fan
- ⑧ Turbo function
- ⑨ Quiet function
- ⑩ On timer setting
- ⑪ Real time clock

Wired controller BRC51A

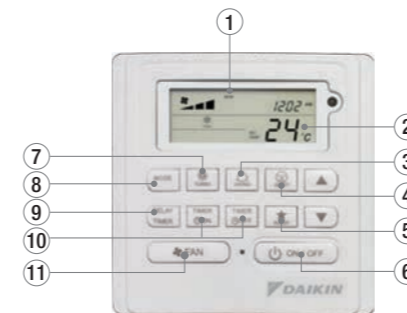

- ① Real time clock and day display
- ② Temperature operate in °C and °F
- ③ Swing function
- ④ Quiet function
- ⑤ Sleep function
- ⑥ ON/OFF switch
- ⑦ Turbo function
- ⑧ Cool, Dry, Fan mode
- ⑨ Delay timer (1 or 2 hours)
- ⑩ 7-days programmable timer
- ⑪ Low, Medium, High, Auto fan speed

Wired controller BRC51A can directly be connected to the unit's main board to start operating without extra setting or modification. It also has a built-in temperature sensor that enables temperature sensing closer to target area for improved comfort (no settings required to activate the handset temperature sensor).

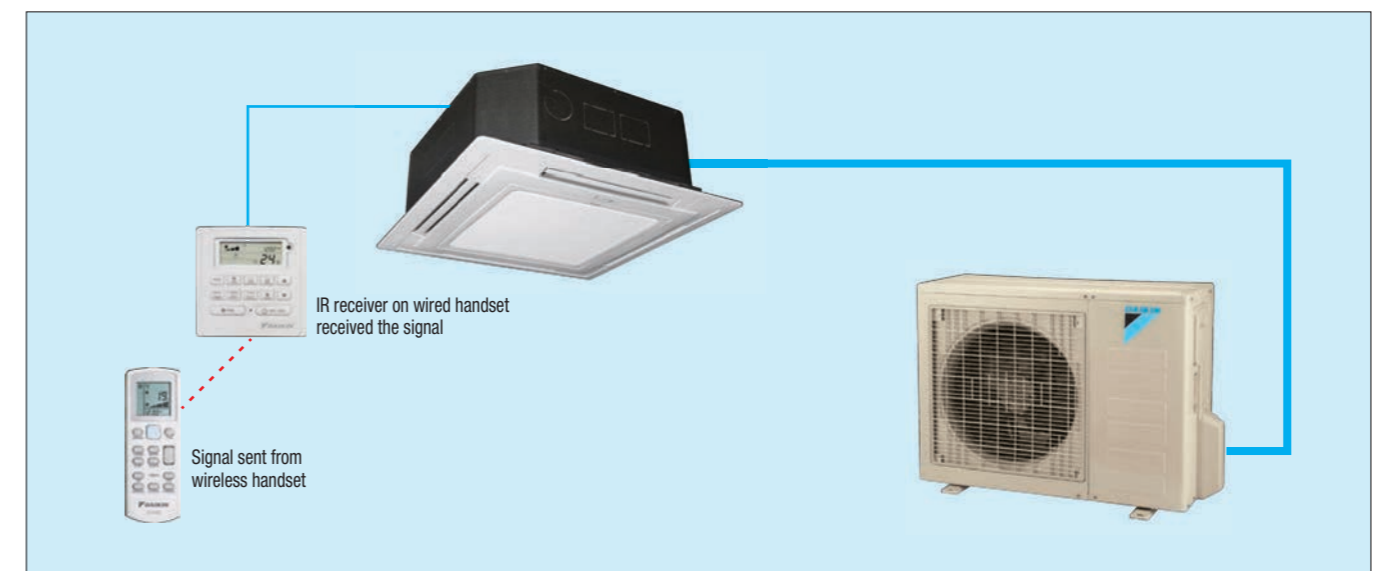

Simple system that provides flexibility of controls

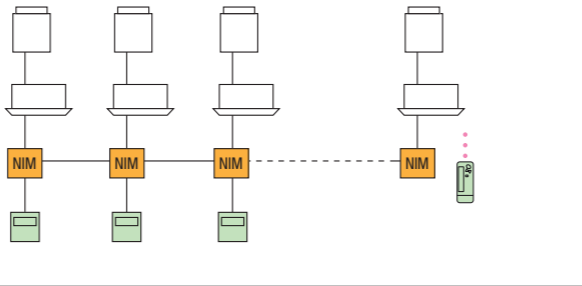
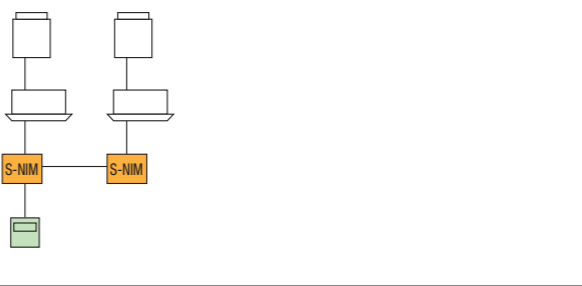
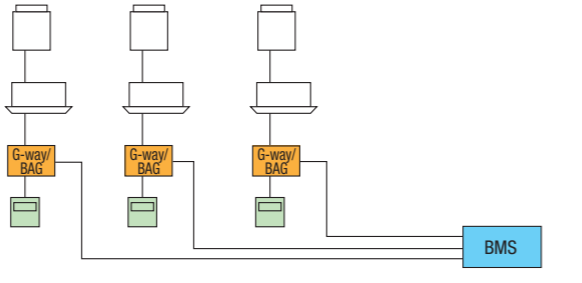
	Control Pattern	Remote Controls
Group control by Network Interface module (NIM)	For simultaneous control of up to 16 indoor units	
Sequential control by Sequential Network Interface Module (S-NIM)	For sequential control of 2 indoor units at alternate sequence of pre-set hour	
Control by external command using G-way or BAG	Operation and surveillance is carried out using the contact signal from the operation control box in the building surveillance (security) room.	

Group control by Network Interface Module (NIM)

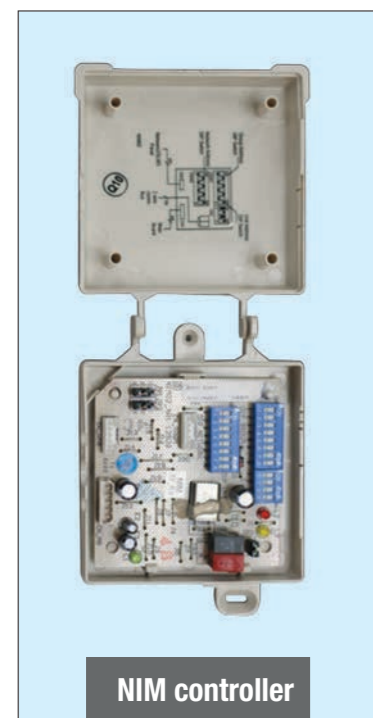

The NIM group controls consist of:

- Mainboard
- Control panel (BRC51A)
- NIM controller
- Communication bus

NIM utilizes master-slave configurations. One master can control up to 15 slave units in a group. The master unit operates in conjunction with a control panel. Any settings done via the control panel connected to the master overwrite the settings of its slave units. Slave units can be operated with or without control panel. If a slave unit is operating with a control panel, its settings can be changed without following its master's.

- DIP switch setting for group and unit address
- Automatic detection of control panel
- Error codes and error unit's ID indication on control panel
- Supported configurations of NIM:

	Master	Slave
BRC51A	•	•
BRC52A		•

Sequential control by Sequential Network Interface Module (S-NIM)

Control two units of air conditioner in a master and slave system, operating at alternate sequence of preset hours (3/4/5/7/9/11/12 hours), controlled by a single BRC51A controller. The S-NIM controls consist of:

- Mainboard
- Control panel (BRC51A)
- S-NIM controller
- Communication bus

The S-NIM is suitable in environment requiring 24-hours air conditioning, such as server room, room containing critical electronics equipment, laboratories, telecommunication towers, railway switching centre and 24-hours shoplets. It also extends the operating lifetime of existing air conditioning units.

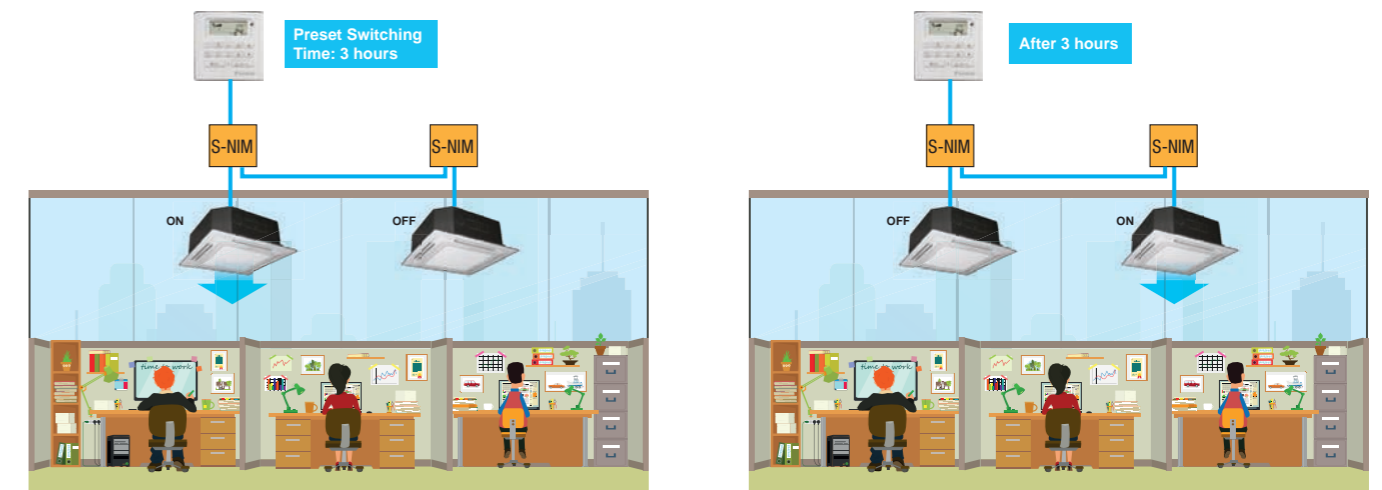

When the operating unit is faulty, the standby unit automatically takes over. Other features of S-NIM:

- Auto restart feature with last state settings.
- Error indication via error code display on the control panel.
- Pre-set operation hours via DIP switch.
- Maximum point to point distance of 1000m.

Control by external command using G-way



The G-way controls consist of:

- Mainboard
- Control panel (BRC51A)
- G-way controller
- Communication bus

It is a gateway between the air conditioning unit and basic Building Management System (BMS). G-way controller enables:

- Remote (ON/OFF) of air conditioner via BMS.
- Unit error indication via BMS and BRC51A controller.
- Unit operation status monitoring via BMS.
- DIP switch setting for control or monitoring function.
- Maximum point-to-point distance of 1000m.

Control by external command using BMS Access Gateway (BAG)



BAG interfaces the air conditioner unit to BMS system via input contacts, resistance inputs and dry contacts outputs which allows the monitoring and controls of the air conditioner. The BAG enables:

- Controls of the air conditioner unit's ON/OFF status, operating mode, fan speed setting, room temperature setting as well as forcing off the unit in the event of fire.
- Indication to warn the control room in the event of air conditioner failure.
- Maximum point-to-point distance of 1100m (please refer to the installation manual)

Inputs	Inputs Controls	Applications
Input contacts	Force off/unchange	Smoke alarm system
	ON/OFF	Long distance unit ON/OFF control
Resistance Inputs	Temperature setting (16°C-30°C)	Long distance unit temperature setting control
Outputs	Output Indications	Applications
Relay outputs	ON/OFF Status	Long distance unit operation status monitoring
	Unit faulty / normal	

The BAG controls consist of:

- Mainboard
- Control panel (BRC51A)
- BAG controller
- Communication bus

Individual air conditioners can be turned on from the control room's Input Contact connection

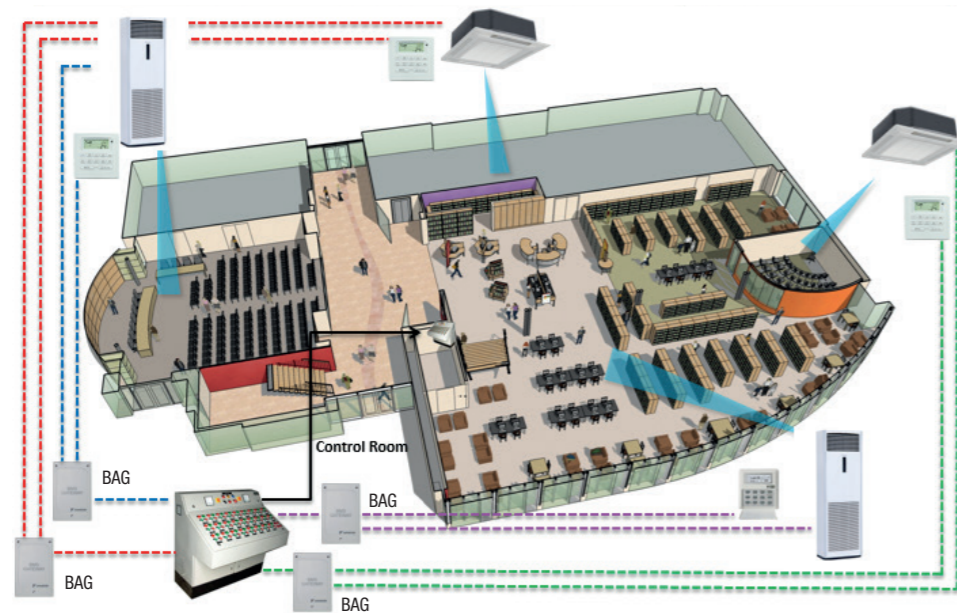

Comparison between G-way controls and BAG controls

Features		G-way	BAG
Input Contacts	Force Off		•
	ON/OFF	•	•
	Operating Mode		•
	Fan Speed		•
Dry Contact Outputs	Set Temperature		•
	ON/OFF Status	•	•
	Operating Mode		•
	Fault Status	•	•

Note:

Communication Bus

A 2-way twisted pair cable is used as the communication bus. Recommended cable for communication bus is a pair of screened & shielded, twisted single core wire with core diameter of 0.5mm to 1.0mm.

Abundance of functions that provide comfortable air-conditioning in stores and offices

Comfort

Auto-swing

Delivers comfortable air-conditioning to all areas, near to and far from the air-conditioner.

Swing pattern selection

You can freely set 3 air discharge setting by remote controller.

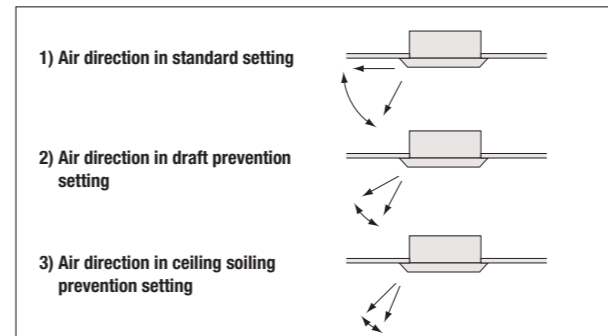

Two selectable temperature-sensors

Temperature-sensors are included in the indoor unit and optional wired remote controller. temperature sensing closer to target area is possible to further increase the comfort level.

Use the temperature-sensor in the indoor unit when controlling air conditioning from another room.

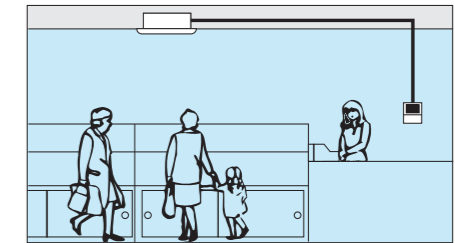

Note: Wireless remote controllers have no temperature-sensor

Switchable fan speed (*available on all models)

Selectable High, Medium and Low fan speed. High setting provides maximum reach while low setting minimizes drafts.

Programme "Dry" (*available on all models)

Dehumidification is microprocessor controlled to prevent abrupt and uncomfortable changes in air temperature. Useful for reducing uncomfortable humidity without uncomfortable cooling of the room.

Timer selector

Operation starts when the preset time of the ON timer elapse and stops when the preset time of the OFF timer elapses.

Weekly schedule timer

Available in Timer 1 & Timer 2 with operation ON/OFF settings programmed for 7 days of the week.

Cleanliness

Washable saranet filter

Removal of air-borne dust particles through saranet filter ensures cleaner air supply.

Work and Servicing

Drain pump mechanism

Steeper gradient realises more efficient condensate drainage. High-lift is especially useful for long lengths of drain piping.

Pre-charge for up to 7.5 metres

If refrigerant piping length does not exceed 7.5m, there is no need for on-site gas charging. However for any piping length more than 7.5m, requires for additional charge.

(Applies for all models)

Self diagnosis function (*available on all models)

The operating parameters of indoor and outdoor units, and sensor data at critical locations throughout the system, are constantly monitored using a microcomputer. This intelligent feature helps to detect faults or malfunctioning in the system and give user a warning by blinking of the LED light on the unit or display error code on the wired controller.

Control features

Auto random restart (*available on all models)

If there is a power outage while the equipment is operating, operations will restart randomly (within 180 to 244 seconds) in the same mode as before the power cut when electricity is restored.

Group control by Network Interface Module (NIM)

You can turn up to 16 indoor units on/off with a single remote controller. (When using connected indoor units, the settings must all be the same and on/off will be simultaneous.)

External command control using G-way or BAG

Operation and surveillance is carried out using the contact signal from the operation control box in the building surveillance (security) room.

Options

Fresh-air intake kit

You can provide air-conditioning with fresh air from outside. It is convenient for places where a ventilation fan cannot be installed.

*Note: * Connecting ducts, insect nets, fire dampers, air filters, and other parts should, as required, be procured locally.*

Specifications

Ceiling cassette

Capacity		PK	2.0	2.5	3.0	3.0	3.5	4.0	
Model	Indoor unit		FCRN50FXV14	FCRN60FXV14	FCRN71FXV14	FCRN71FXV14	FCRN100FXV14	FCRN125FXV14	
	Outdoor unit		RN50CXV1A4	RN60CXV1A4	RR71CXV1A4	RR71CXV1A4	RR100DXV1A4	RR125DXV1A4	
	Decoration panel		BC50F2XW4						
Nominal cooling capacity	Btu/hr		18,500	23,000	28,000	28,000	36,000	42,000	
	kW		5.4	6.8	8.2	8.2	10.6	12.3	
Nominal total input power	W		1,760	2,050	2,930	2,900	3,660	4,110	
Nominal COP	W/W		3.08	3.29	2.80	2.83	2.88	3.00	
Power supply	V/Ph/Hz		220-240/1/50 (power from outdoor)			380-415/3/50 (power from outdoor)			
Indoor unit	Airflow (H/M/L/Q)	cfm	730/620/510/360	840/700/560/440	890/760/620/490	890/760/620/491	1030/870/730/580	1120/1030/890/760	
	Sound pressure level (H/M/L/Q)	dB(A)	38/35/33/29	39/37/34/31	41/38/35/32	41/38/35/33	46/41/37/34	48/45/41/37	
	Dimensions (HxWxD)	Unit	mm	246x840x840	246x840x840	246x840x840	246x840x841	288x840x840	288x840x840
		with decoration panel	mm	301x950x950	301x950x950	301x950x950	301x950x951	343x950x950	343x950x950
Machine weight	Unit	kg	22	22	22	22	25	25	
	decoration panel	kg	5	5	5	5	5	5	
Outdoor unit	Sound pressure level	dB(A)	52	52	56	56	58	60	
	Dimensions (HxWxD)	mm	651x855x328	651x855x328	753x855x328	753x855x329	852x1030x400	852x1030x400	
	Machine weight	kg	43	47	57	56	71	95	
	Piping connections	Liquid (Flare)	mm	6.35	6.35	9.52	9.52	9.52	9.52
		Gas (Flare)	mm	12.70	15.88	15.88	15.88	15.88	15.88
	Max. interunit piping length	m	30	30	45	45	50	50	
	Max. installation level difference	m	15	15	25	25	30	30	

1. Rated cooling capacities are based on the following conditions: Indoor temp. 27°CDB, 19°CWB; outdoor temp. 35°CDB; piping length: 7.5m

Floor standing

Capacity		PK	3.0	3.0	3.5	4.0	5.0	
Model	Indoor unit		FVRN71BXV14	FVRN71BXV14	FVRN100BXV14	FVRN125BXV14	FVRN140BXV14	
	Outdoor unit		RR71CXV1A4	RR71CXV1A4	RR100DXV1A4	RR125DXV1A4	RR140DXV1A4	
Nominal cooling capacity	Btu/hr		29,000	28,000	36,000	42,000	55,000	
	kW		8.5	8.2	10.6	12.3	16.1	
Nominal total input power	W		2,900	2,850	3,550	4,100	5,490	
Nominal COP	W/W		2.93	2.88	2.97	3.00	2.94	
Power supply	V/Ph/Hz		220-240/1/50 (power from outdoor)		380-415/3/50 (power from outdoor)			
Indoor unit	Airflow (H/M/L)	cfm	675/625/530	675/625/530	1035/945/845	1035/945/845	1170/1085/985	
	Sound pressure level (H/M/L)	dB(A)	44/42/39	44/42/39	49/47/44	49/47/44	54/53/51	
	Dimensions (HxWxD)	mm	1850x600x270	1850x600x270	1850x600x350	1850x600x350	1850x600x350	
	Machine weight	kg	42	42	45	45	51	
Outdoor unit	Sound pressure level	dB(A)	56	56	58	60	65	
	Dimensions (HxWxD)	mm	753x855x328	753x855x328	852x1030x400	852x1030x400	852x1030x400	
	Machine weight	kg	57	56	71	95	105	
	Piping connections	Liquid (Flare)	mm	9.52	9.52	9.52	9.52	9.52
		Gas (Flare)	mm	15.88	15.88	15.88	15.88	19.05
	Max. interunit piping length	m	45	45	50	50	45	
Max. installation level difference	m	25	25	30	30	25		

1. Rated cooling capacities are based on the following conditions: Indoor temp. 27°CDB, 19°CWB; outdoor temp. 35°CDB; piping length: 7.5m

Note:

A series of horizontal dotted lines for writing notes.